

35040

R/C Loco Receiver, 3A, with Pocket Remote

1. General information

Thank you for purchasing the PIKO R/C system for radio operation of garden railway models.

Please read these operating instructions carefully in order to be able to use all the functions of this device. It is essential that you observe the following safety and warning instructions to ensure trouble-free and safe operation of your model.

With this set you can retrofit an analogue locomotive for radio operation. With the main circuit board (receiver), a switch plate and a transmitter (remote control), you receive all the components for radio operation. It is possible to supply the system with battery voltage* or permanent track voltage. In addition, two switching functions / sound functions (depending on the locomotive equipment) are switchable.

*Batteries or battery holders are not included in the set.

2. Safety & warning information

The remote control system has been designed and approved exclusively for the control of RC models. PIKO Modellbau assumes no liability in the event of any other use. Remote-controlled models are not toys and only suitable for model railroaders aged 14 and over. The construction and operation of such models requires special knowledge, technical care, technical understanding and careful, safety-conscious behaviour. Errors during assembly or operation can cause considerable damage to property and personal injury. As manufacturers and sellers, we are unable to monitor the operation of our products. Therefore we do not assume any liability. Technical defects of an electrical or mechanical nature can lead to the unexpected starting of a motor, which can seriously injure not only you! Even an operation of the receiver system without activated

transmitter can lead to this effect. Protect your remote control system from dust, dirt and moisture. Do not expose the devices to excessive heat, cold or vibration. The remote control operation may only be carried out in the specified temperature range from -15°C to +55°C. Avoid shock and pressure loads. Always check your remote control for damage to housings, cables and connections.

3. Content:

1x Transmitter (Pocket remote)

1x Receiver (main PCB)

1x PCB with switch

1x Cable (2-pole, gray-white)

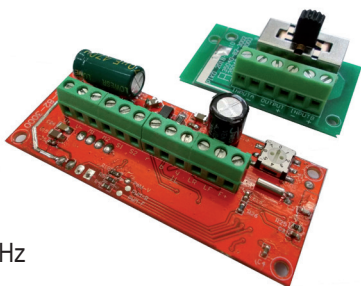

3.1 Technical data

Transmitter (Pocket Remote)

Number of channels:	8
Frequency range:	2.4 GHz
Range approx.:	30 m
Power supply:	1x 3 V CR2025
Dimensions approx.:	2.68" x 1.42" x 0.63" (68 x 36 x 16 mm)
Weight approx.:	30 g

Receiver (Main PCB)

Number of channels:	8
Speed steps:	14 (bei 7-16 V) 28 (bei 16-24 V)
Frequency range:	2.4 GHz
Range approx.:	30 m
Power supply:	7 - 24 V DC / 6 - 18 V AC
max. current:	3A
Dimensions approx.:	2.72" x 1.14" x 0.59" (69 x 29 x 15 mm)
Weight approx.:	40 g

4. Control elements

vorwärts - ansteigend
(rückwärts - absteigend)
*forwards - step up
(reverse - step down)*

rückwärts - ansteigend
(vorwärts - absteigend)
*reverse - step up
(forwards - step down)*

Funktion 1
*Function 1
Sound 1**

Funktion 2
*Function 2
Sound 2**

Not-Stopp
Emergency stop



* entsprechendes Equipment (Decoder) erforderlich
special supporting equipment (Decoder) is required

5. First set-up

The transmitter requires a CR2025 battery for operation. There is a LED at the top of the remote that confirms each operation. If the brightness or range of the remote control decreases, the battery must be replaced.

Proceed as follows:

- To insert the cell, lever open the lid with a coin on the recess.
- Carefully insert the button cell into the holder with the plus pole facing up.
- Place the metal bracket back into the bottom of the housing and join the two halves of the housing together.

6. Connections on the receiver

ATTENTION: The correct polarity of the supply voltage must be observed. The existing cables are connected via a screw terminal.

So that the receiver can receive the signals from the transmitter, it must be connected to the appropriate transmitter. This is done by a simple channel selection via a DIP turn switch.

6.1 Installation

The installation of the circuit boards depends individually on the model and the equipment. The main board has the same dimensions as our standard circuit board or decoder. Thus the available space can be used. Usually the existing main board is replaced with the new R/C board. A suitable place must be found for the switch circuit board. It is important that the solder joints of the printed circuit boards are not in contact with metal parts in the locomotive, otherwise short circuits will result.

ATTENTION! If the system is used with permanent track voltage, the switch PCB must be properly mounted on a metal weight. On the one hand to cool the rectifier and on the other hand to protect it from damage by hot parts. However, make sure that the solder joints are properly insulated!

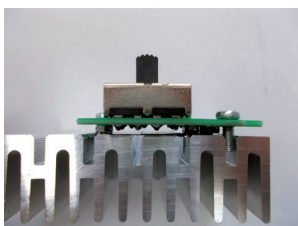
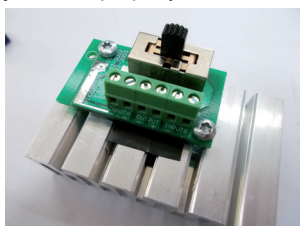

The experienced modeler will integrate the R/C circuit board to the analog sound or sound decoder. The existing supply lines must be separated and extended accordingly. The following illustrations show the possibilities.

Attention! These steps should only be carried out by experienced model railroaders.

6.1.1 Direct installation

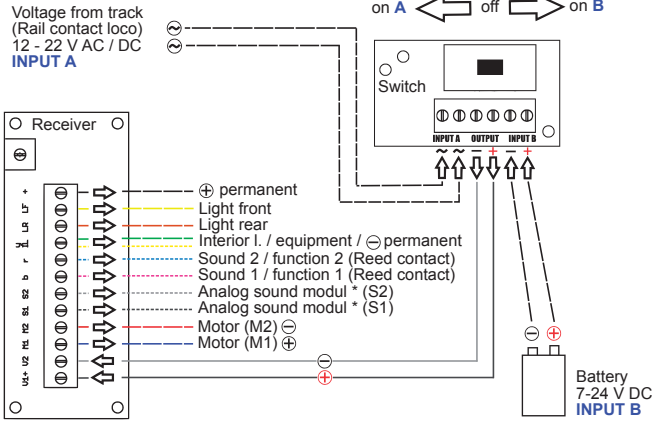

* e.g. #36194 PIKO G Sound Kit (analog)

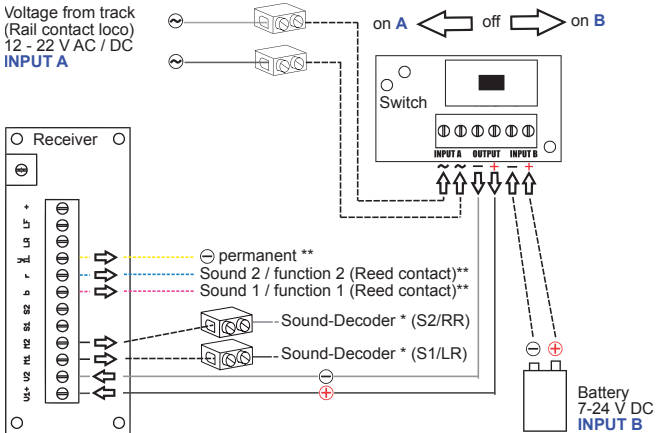

6.1.2 Parallel installation

on ← off →

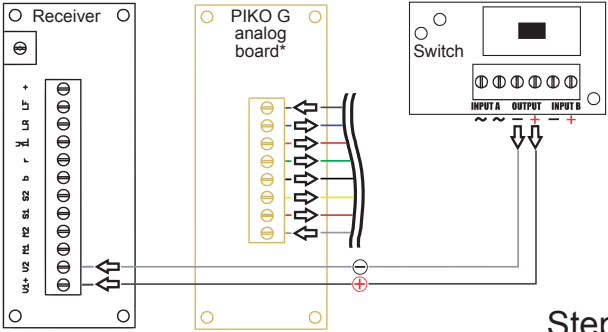

Step 1

on ← off →

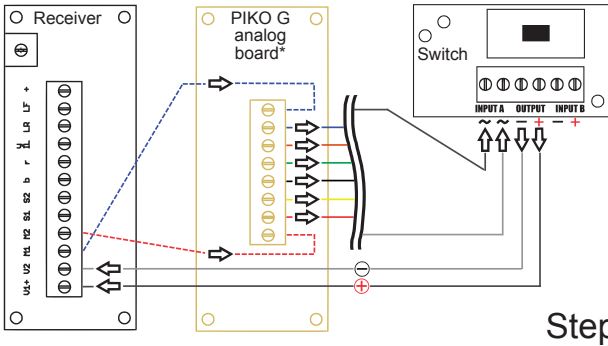

Step 2

* Fitted as standard in many PIKO G-scale locos. See in the locos instruction manual.

7. Channel selection / Synchronization

In order for the receiver to pick up the signals from the transmitter, it must be connected to the corresponding transmitter. This is done by simply selecting a channel using a DIP rotary switch.

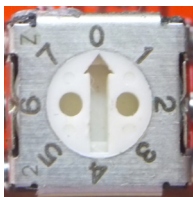

The transmitter and receiver are factory-set to channel 0.



Transmitter:

1. Remove the small cover on the back of the transmitter.
2. You now have access to the DIP rotary switch.
3. The arrow direction indicates the set channel.
4. You can adjust the channel by turning it with a small fl at screwdriver. Transmitter and receiver must be synchronized accordingly.

Receiver:

1. Depending on the installation position, you need access to the DIP turn switch on the main circuit board
2. The direction of the arrow indicates the channel that has been set.
3. As with the transmitter, use a small flat screwdriver to set the channel on the DIP turn switch.

Transmitter and receiver must therefore be synchronized accordingly.

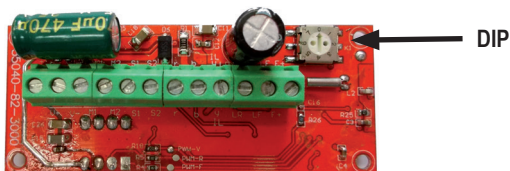



8. Operation

First make sure that you have switched on the switch board!

The operation is simple. By pressing the buttons on the remote control, you can select the direction of travel/speed level and, depending on the range of functions/further accessories, even trigger 2 sound functions*.

1 x  = Forward driving direction, speed level 1

2 x  = Forward driving direction, speed level 2

If you are already driving forwards with the locomotive, you can use the button  to increase the speed (speed levels).

By pressing , you can decrease the speed.

1x  = Reverse driving direction, speed level 1

2x  = Reverse driving direction, speed level 2

If you are already reversing with the locomotive, you can use the button  to increase the speed (speed steps).

Press the button  to reduce the speed.

You can press the buttons briefly, which only changes one speed step at a time, or you can keep the buttons pressed, which causes the speed to change continuously.

 } = Emergency stop

 = Sound triggering 1, e.g. a bell*

 = Sound triggering 2, e.g. a horn*

*Only in combination with appropriate accessories with Reed contact tripping.

REGULATORY INFORMATION

FCC ID: 2ATRN-35041

FCC Information (USA):

This device complies with part 15 of the FCC Rules. Operation is subject to the following two conditions: (1) This device may not cause harmful interference, and (2) this device must accept any interference received, including interference that may cause undesired operation.

